

GEOHERMAL TUNNEL LINING

AGENDA

- 10.00 - 10.20 Registration & Coffee
10.20 - 10.30 Introduction & Welcome Mark Thurston Crossrail
- 10.30 - 11.00 Delivering a sustainable Crossrail
- Mike de Silva, Crossrail
- 11.00 - 11.30 Principles of Geothermal Tunnel Lining
- Duncan Nicholson, Arup
- 11.30 - 11.45 Coffee
11.45 - 12.15 Geothermal Tunnel Lining project from across the globe
- Ralf Winterling REHAU
- 12.15 - 12.45 Cooling urban railways
- Mark Gilbey and Jolyon Thompson, Parsons
- Brinckerhoff
12.45 - 13.15 Q&A
13.15 Lunch, with optional tour of the Crossrail Tunnelling Academy

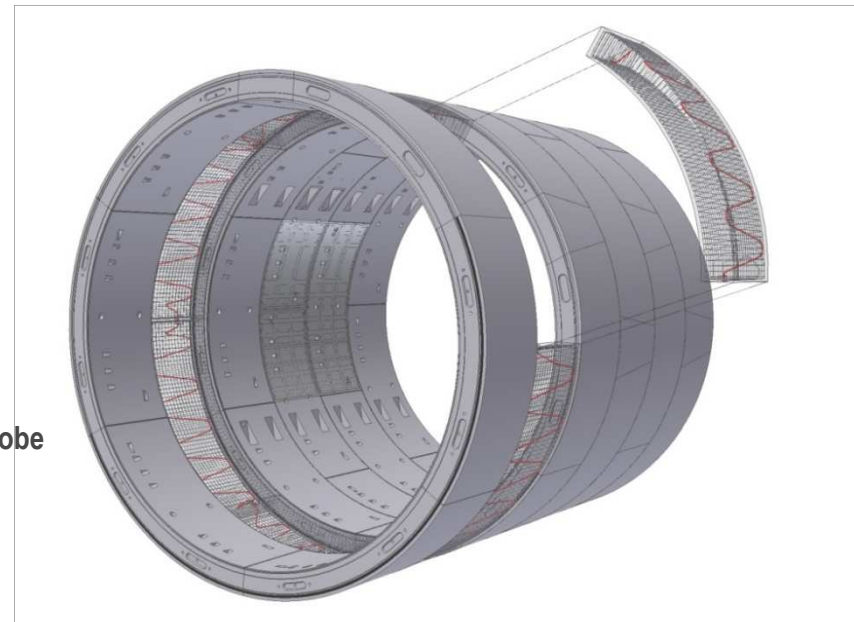

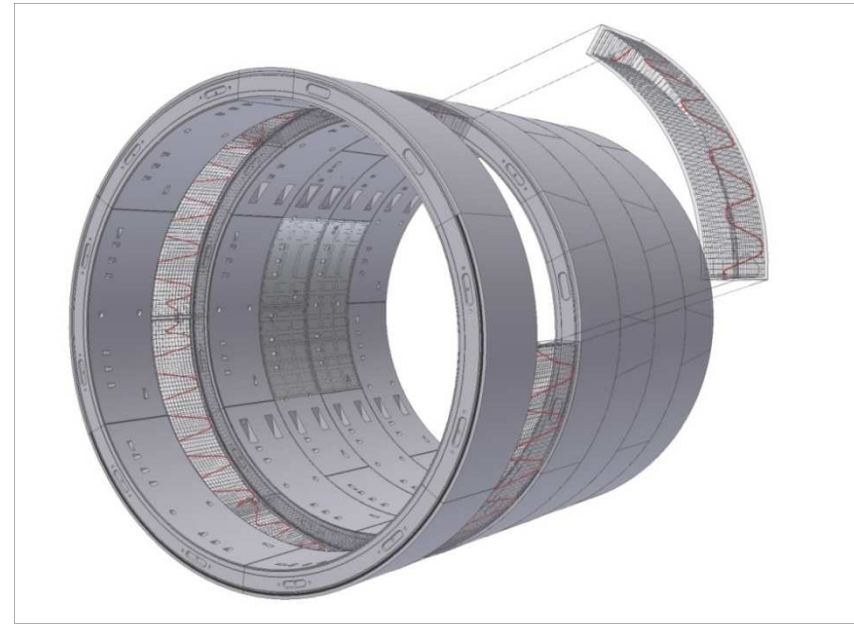

GEOHERMAL TUNNEL LINING

PROJECTS FROM ACROSS THE GLOBE

RALF WINTERLING, LONDON 2012

GEOTHERMAL TUNNEL LINING

TURNING INFRASTRUCTURE INTO ENERGY SOURCES

1. **REHAU Introduction**
2. Open/closed loop system
3. Principles of Geothermal Tunnel Lining
4. Case Study: Jenbach - Austria
5. Case Study: U6 Stuttgart – Germany
6. Summary



Won Awards 2011

REHAU

UNLIMITED POLYMER SOLUTIONS

REHAU is a leading polymer specialist thanks to our competence in the three business divisions, i.e. Construction, Automotive and Industry.



Construction business division

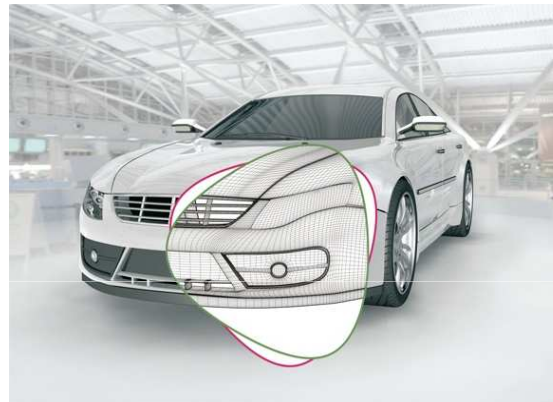

Automotive business division

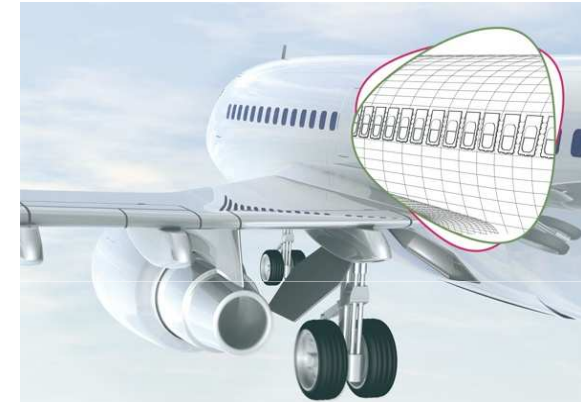

Industry business division

Turnover worldwide: Construction: 50%, Automotive: 25%, Industry: 25%

REHAU

OUR POSITION IN THE MARKET

REHAU is a family-owned, internationally positioned company.

- turnover of the REHAU group: approx. 2,5 bn EUR
- more than 15,000 employees
- subdivided into 8 regions
- 170 locations worldwide
- 41 plants

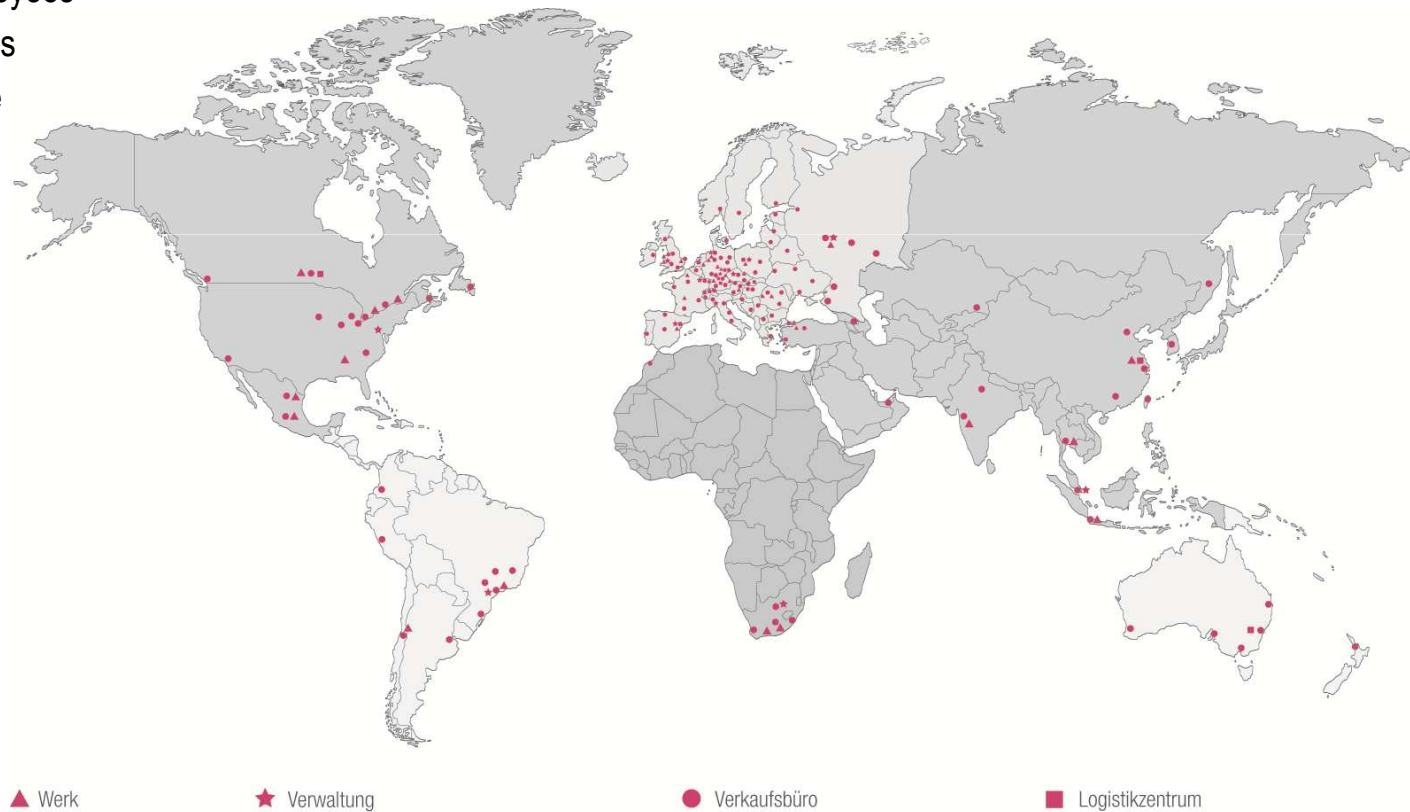

REHAU IN REHAU

- approx. 2,000 employees
- research and development competence is located here



Plant Reha / Scandium



Research and Development



Head office Reha

CONSTRUCTION BUSINESS DIVISION

SUSTAINABLE AND ECONOMICAL SYSTEM SOLUTIONS

As the leading supplier of polymer-based solutions in the field of Construction, REHAU systematically revolutionizes ecology and economy, design and functionality as well as safety and convenience in construction.

Range of services:

- windows and curtain walling technology
- heating&plumbing technology
- electrical installation
- renewable energies
- civil engineering

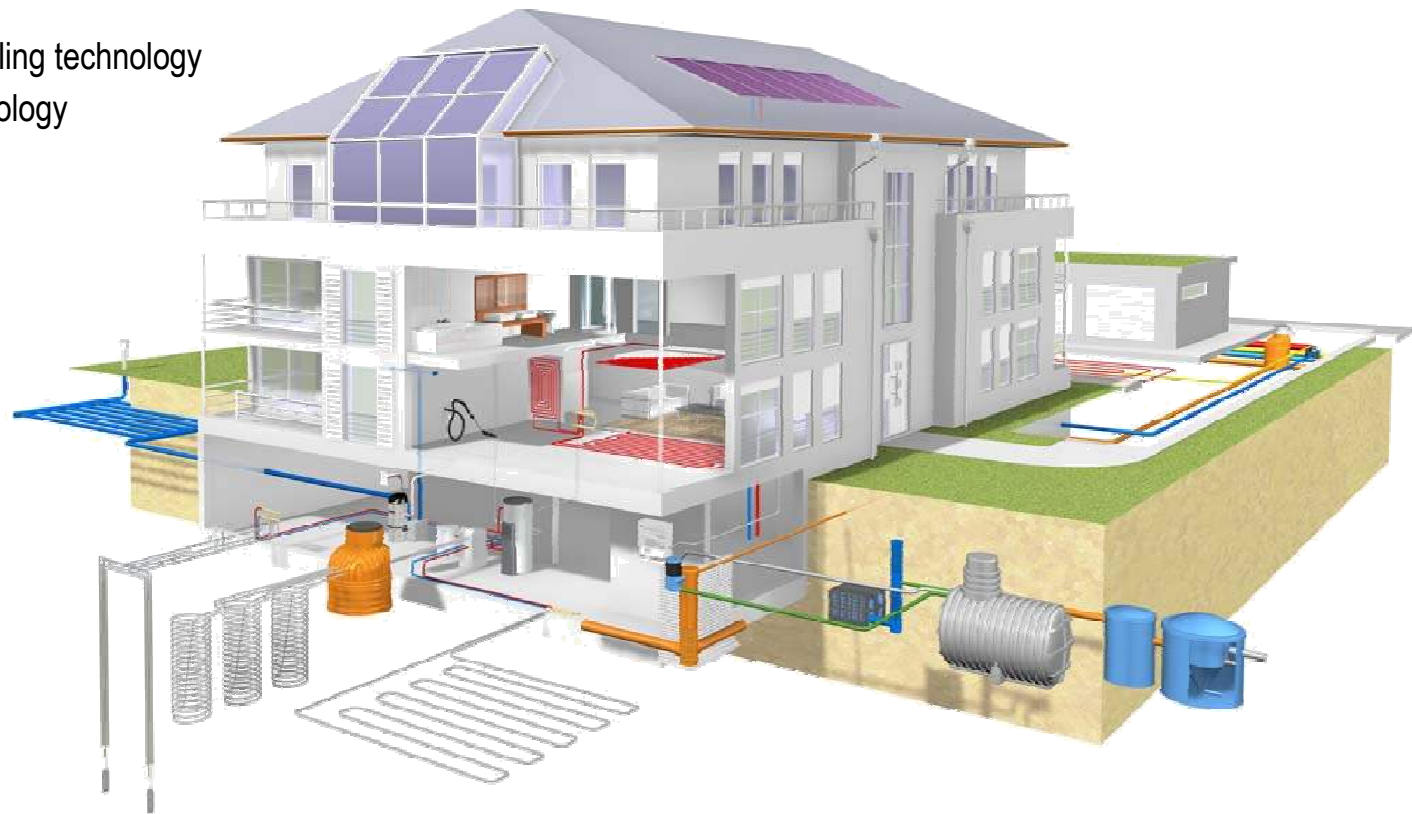

GEOTHERMAL TUNNEL LINING

TURNING INFRASTRUCTURE INTO ENERGY SOURCES

1. REHAU Introduction
- 2. Open/closed loop system**
3. Principles of Geothermal Tunnel Lining
4. Case Study: Jenbach - Austria
5. Case Study: U6 Stuttgart – Germany
6. Summary

GEOHERMAL TUNNEL LINING

OPEN / CLOSED LOOP SYSTEM

Open System

- Warm tunnel drainage water as energy source
- Collection via drainage pipes
- Long, deep tunnel (base tunnel)



Closed Loop System

- Energy exchange via closed loop absorber pipe work
- Absorber system integrated in concrete structure
- Urban tunnel (Metro-Tunnel)



GEOHERMAL TUNNEL LINING

OPEN / CLOSED LOOP SYSTEM

THERMAL USE OF TUNNEL WATER – GOTTHARD BASE TUNNEL

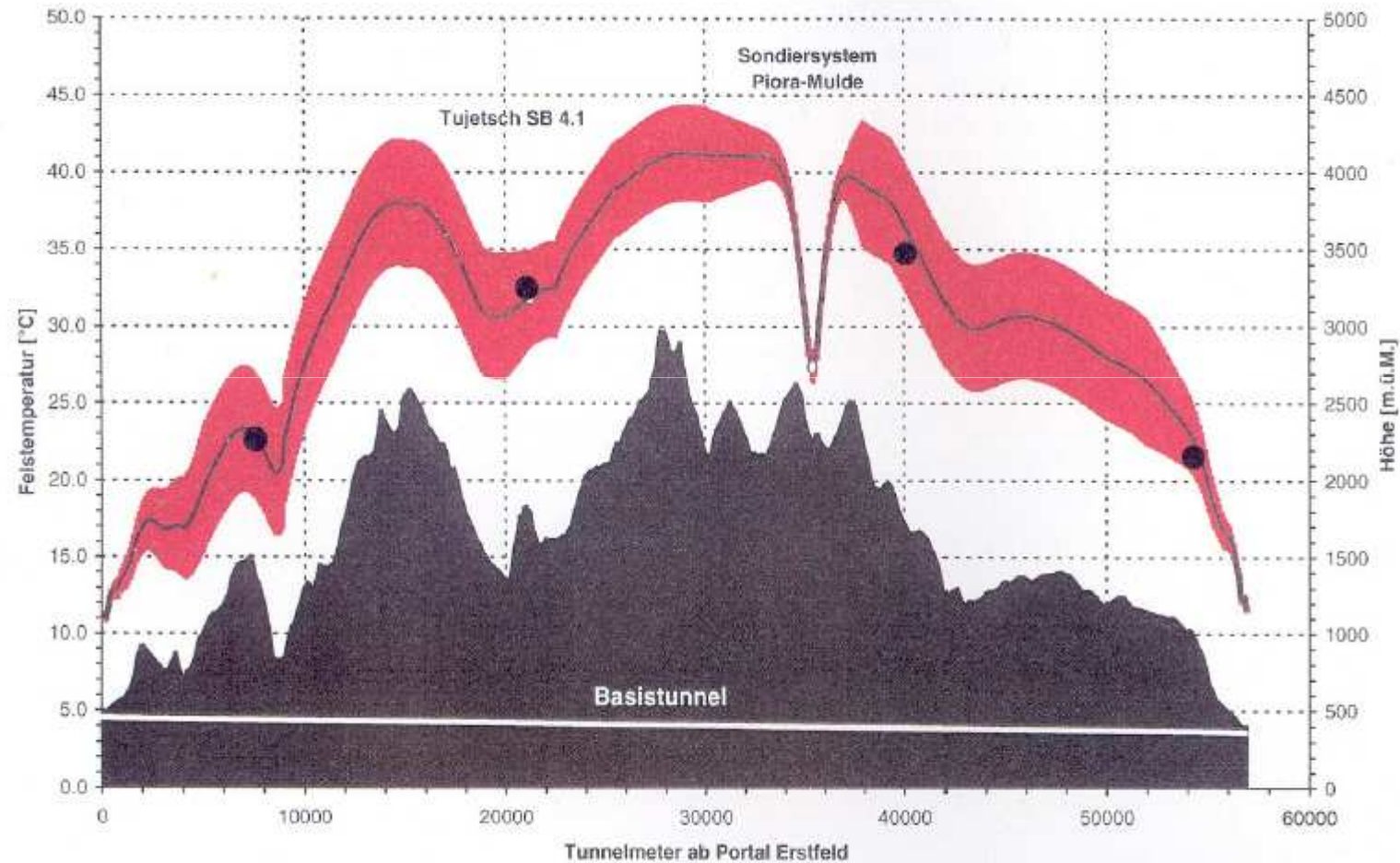

Image: Wilhelm, J., Rybach, L., 2003

GEOTHERMAL TUNNEL LINING

OPEN / CLOSED LOOP SYSTEM

THERMAL USE OF TUNNEL WATER – LÖTSCHBERG & FURKA TUNNEL

Lötschberg Tunnel:

- Fish farm Frutigen
- Tunnel water flow rate 100 l/s, 19 °C
- Heat flux 6.8 MW



Furka Tunnel:

- Space heating for Hotels in Oberwald
- Tunnel water flow rate 90 l/s, 16 °C
- Heat flux 3.7 MW



Image: above: www.tropenhaus-frutigen.ch;

below: Wilhelm, J., Rybach, L., 2003

GEOTHERMAL TUNNEL LINING

THERMAL USE OF TUNNEL WATER – DRAINAGE SYSTEM RAUDRIL RAIL PP

- High ring stiffness SN8 in slotted condition
- Very low abrasion due to RAUSISTO formulation
- Very good drainage values enable installation at a very low gradient
- Proven ability to withstand high-pressure rinsing up to 340 bar
- Cleaning with chain scraper possible and proven
- Approved by Deutsche Bahn AG
- Meets the German, Austrian and Swiss requirements for tunnel construction
- Swiss regulation AQV Tunnel Drainage demands PP Pipe material for Tunnel Constructions with a temperature $> 30^{\circ}\text{C}$



Rounded slots in TP / MP / LP-pattern according to DIN 4262-1



Comprehensive range of system accessories

GEOTHERMAL TUNNEL LINING

TURNING INFRASTRUCTURE INTO ENERGY SOURCES

1. REHAU Introduction
2. Open/closed loop system
- 3. Principles of Geothermal Tunnel Lining**
4. Case Study: Jenbach - Austria
5. Case Study: U6 Stuttgart – Germany
6. Summary

GEOTHERMAL TUNNEL LINING

PRINCIPLES

Absorber pipes are integrated in the tunnel concrete structure, either in pre-fabricated segments or conventional in-situ concrete.

By circulating a heat transfer fluid through the pipes the concrete structure gets thermally activated **to transfer energy for heating and cooling purposes.**

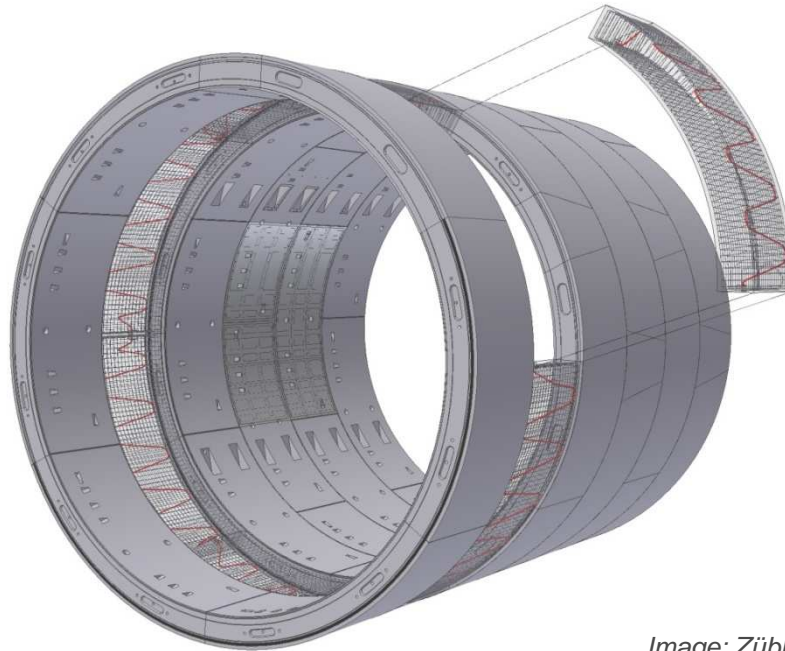

Image: Züblin

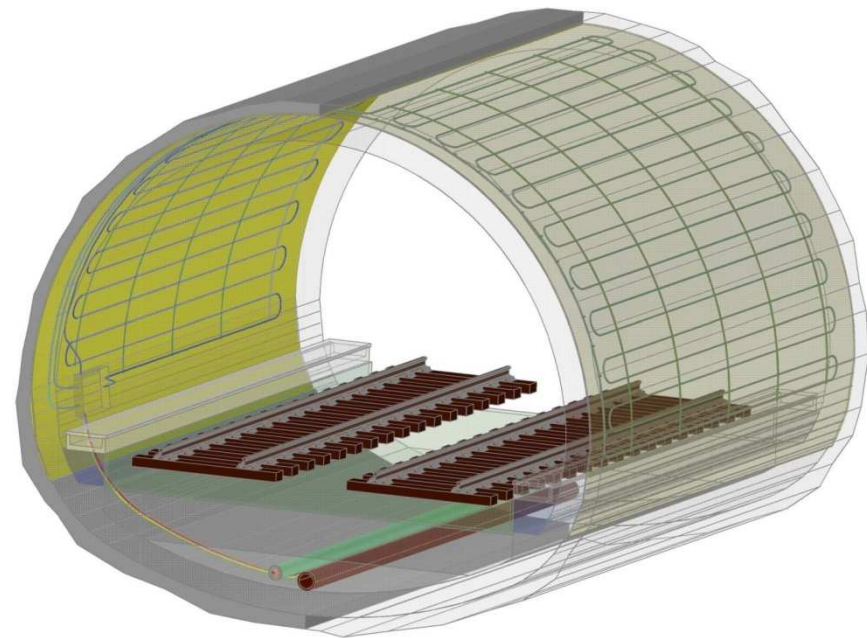
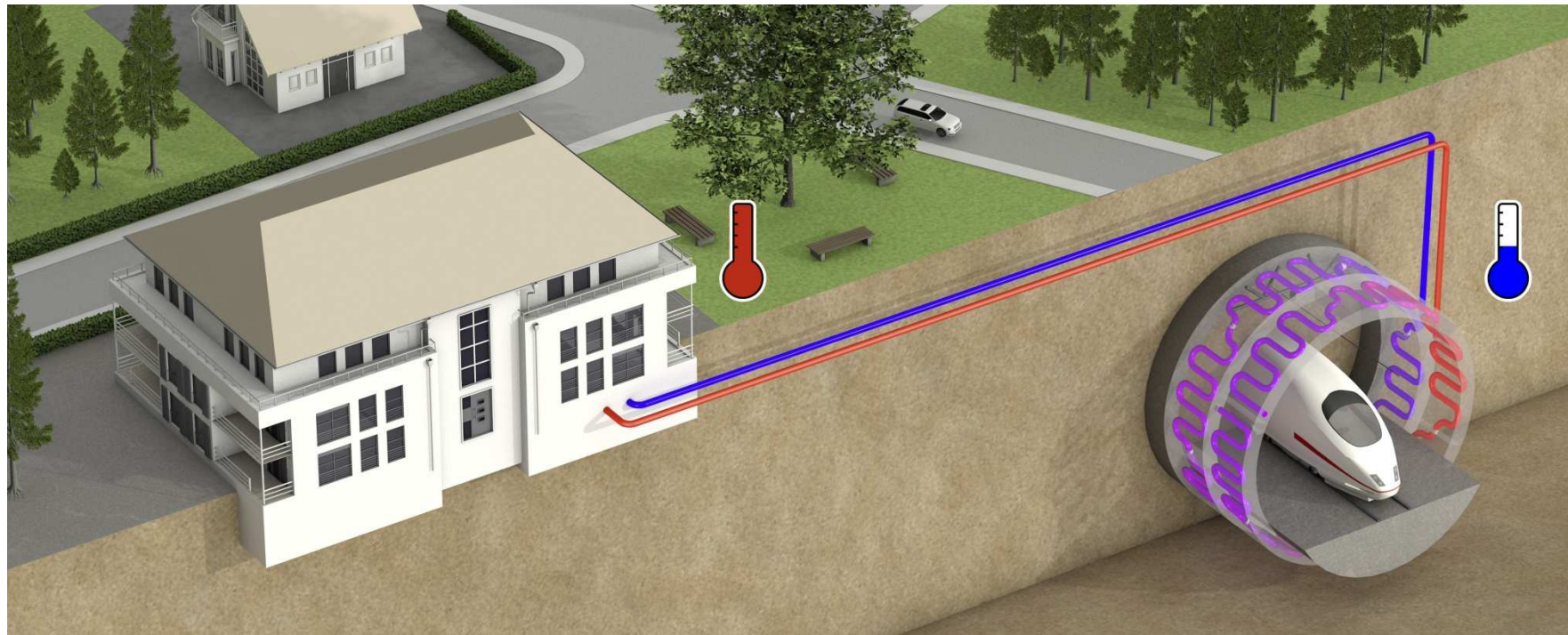

Image: PSP

GEOHERMAL TUNNEL LINING

PRINCIPLES



Thermally activated tunnel structure to **harvest ground source energy** to heat buildings above ground.

GEOTHERMAL TUNNEL LINING

PRINCIPLES

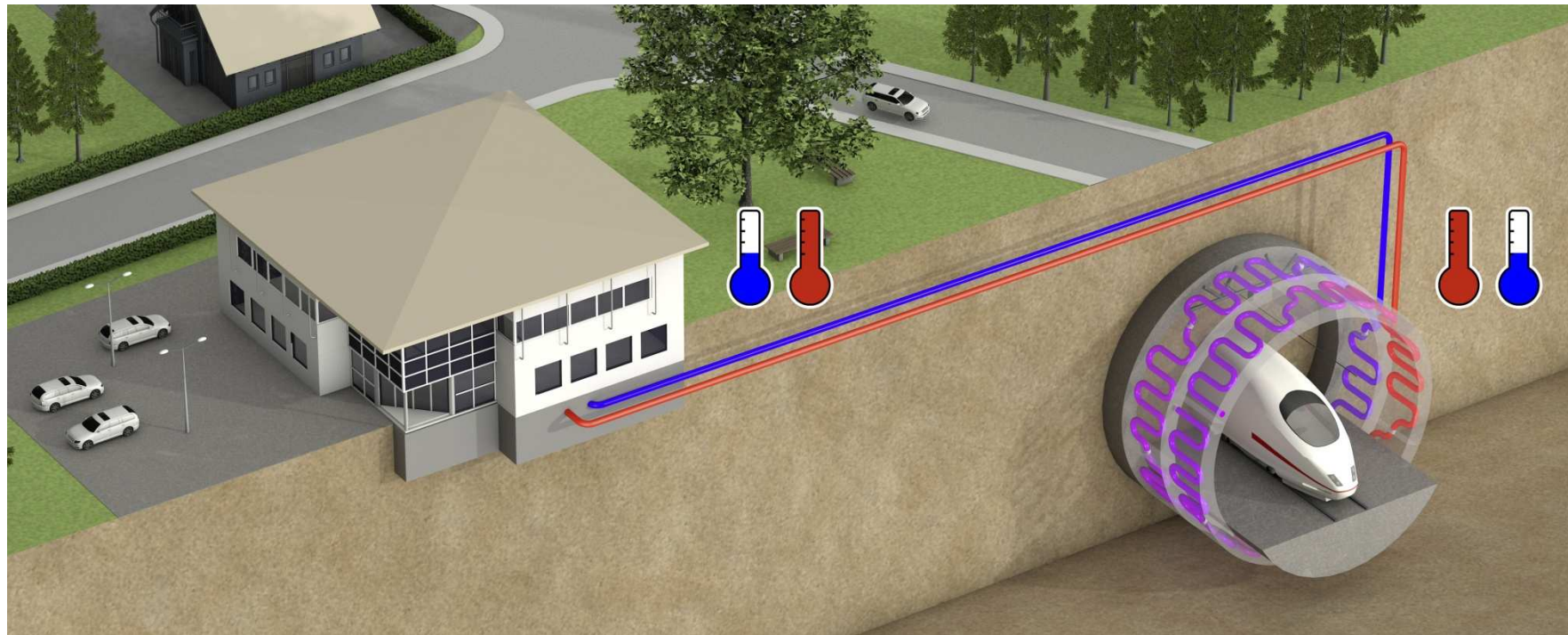

Thermally activated tunnel structure to cool buildings above ground by using the **tunnel as heat sink** in summer and heat source in winter.

GEOTHERMAL TUNNEL LINING

PRINCIPLES

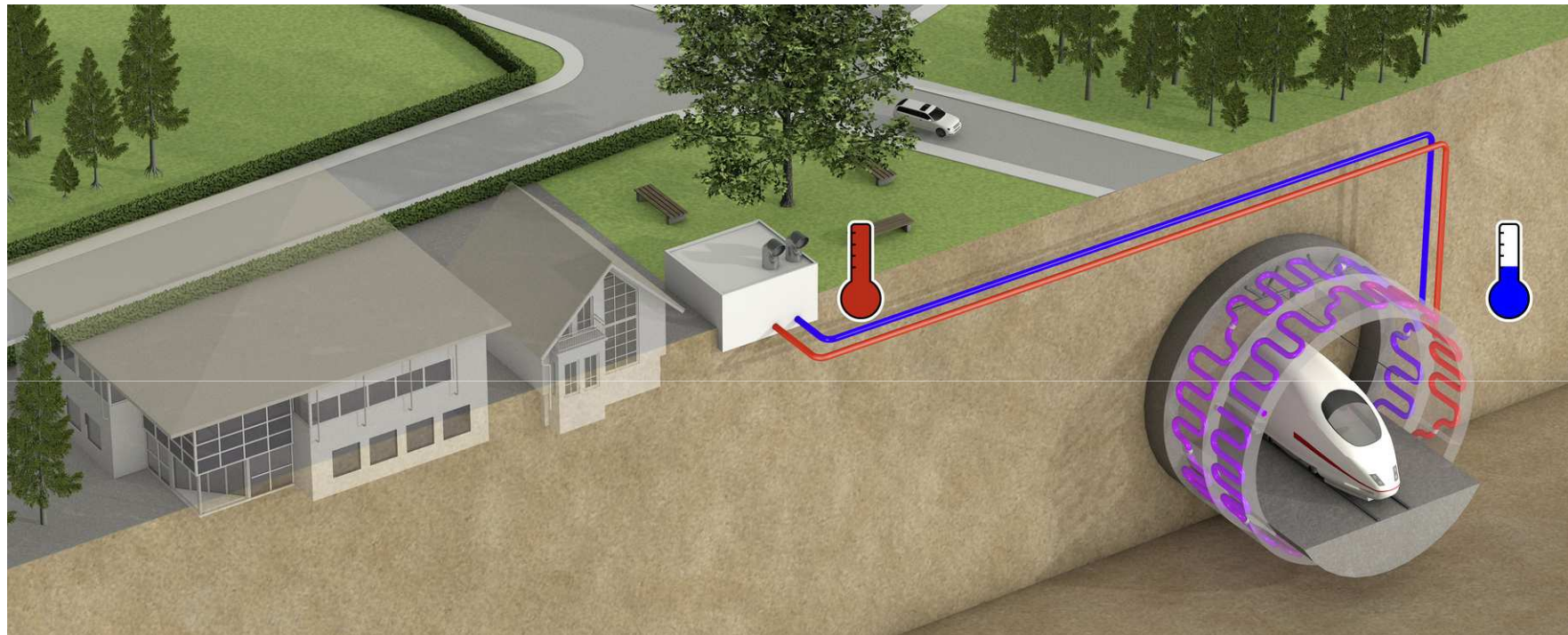

Thermally activated tunnel structure to **cool the tunnel** in case of hot climate and/or considerable amount of heat build up through tunnel operation. Extracted energy can get used in above ground buildings or dissipated to the atmosphere via a chiller.

TUNNEL ENERGY LINING

BENEFITS OF REHAU PE-Xa PIPES

- High resistance against notches, grooves and punctual loads through crosslinked PE



Test Results of Notch Tests & Full Notch Creep Tests (FNCT) in Hours

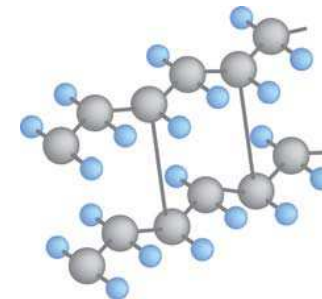
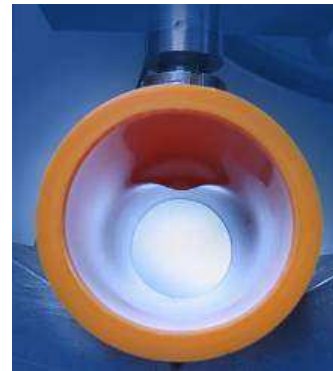

- Tight bending radii possible

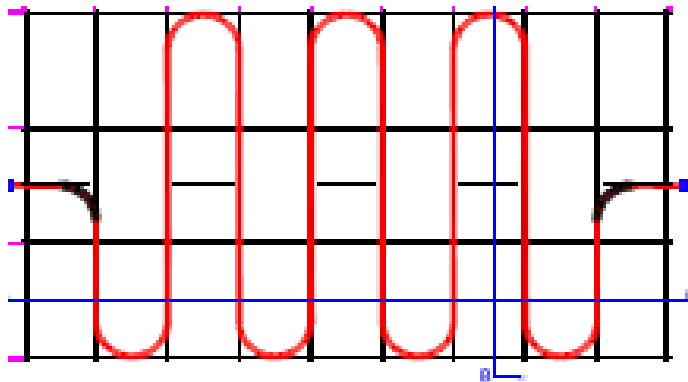

- Connection with REHAU-Everloc™ Fitting

TUNNEL ENERGY LINING

PIPE CONNECTIONS VIA REHAU-EVERLOC™ FITTING

Connection between the Tunnel Segments via permanent mechanical connection, REHAU Everloc™ Fitting.



- Minimal space required for connection
- Simple and fast installation
- High pressure resistant
- Permanently tight connection without sealing rings



GEOTHERMAL TUNNEL LINING

TURNING INFRASTRUCTURE INTO ENERGY SOURCES

1. REHAU Introduction
2. Open/closed loop system
3. Principles of Geothermal Tunnel Lining
- 4. Case Study: Jenbach – Austria**
5. Case Study: U6 Stuttgart – Germany
6. Summary

GEOHERMAL TUNNEL LINING

CASE STUDY JENBACH, AUSTRIA

Project Data:

Northern approach of the Brenner Base Tunnel

3,470 m new twin track high-speed rail tunnel

Construction: Tunnel Boring Machine

Tunnel diameter: approx. 12 m

Activated Tunnel Length: 54 m

Contractor:

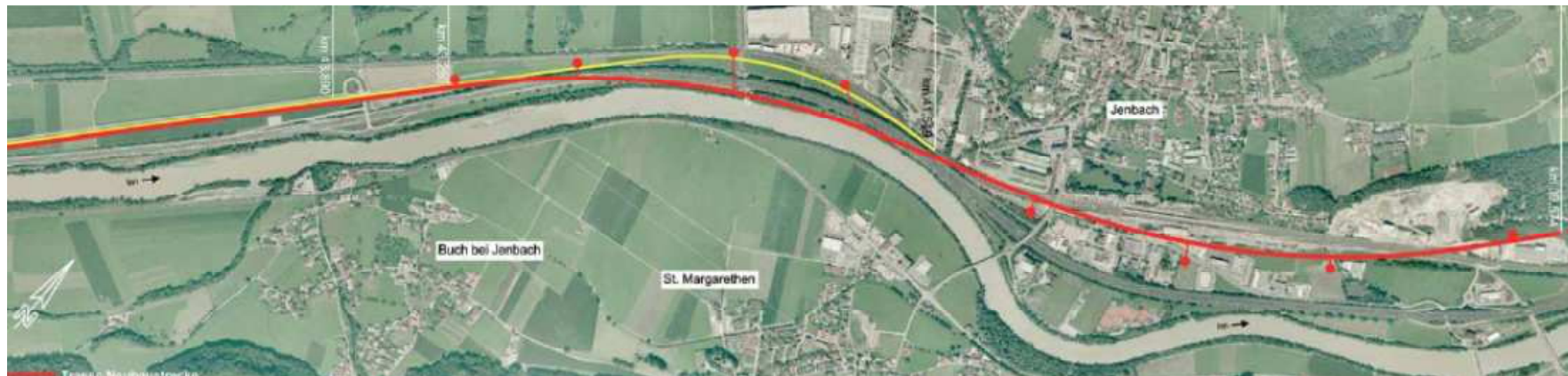

Image: BB, Section H8

GEOHERMAL TUNNEL LINING

3. CASE STUDY JENBACH, AUSTRIA

Demonstrator project designed and realised by Ed. Züblin AG & REHAU

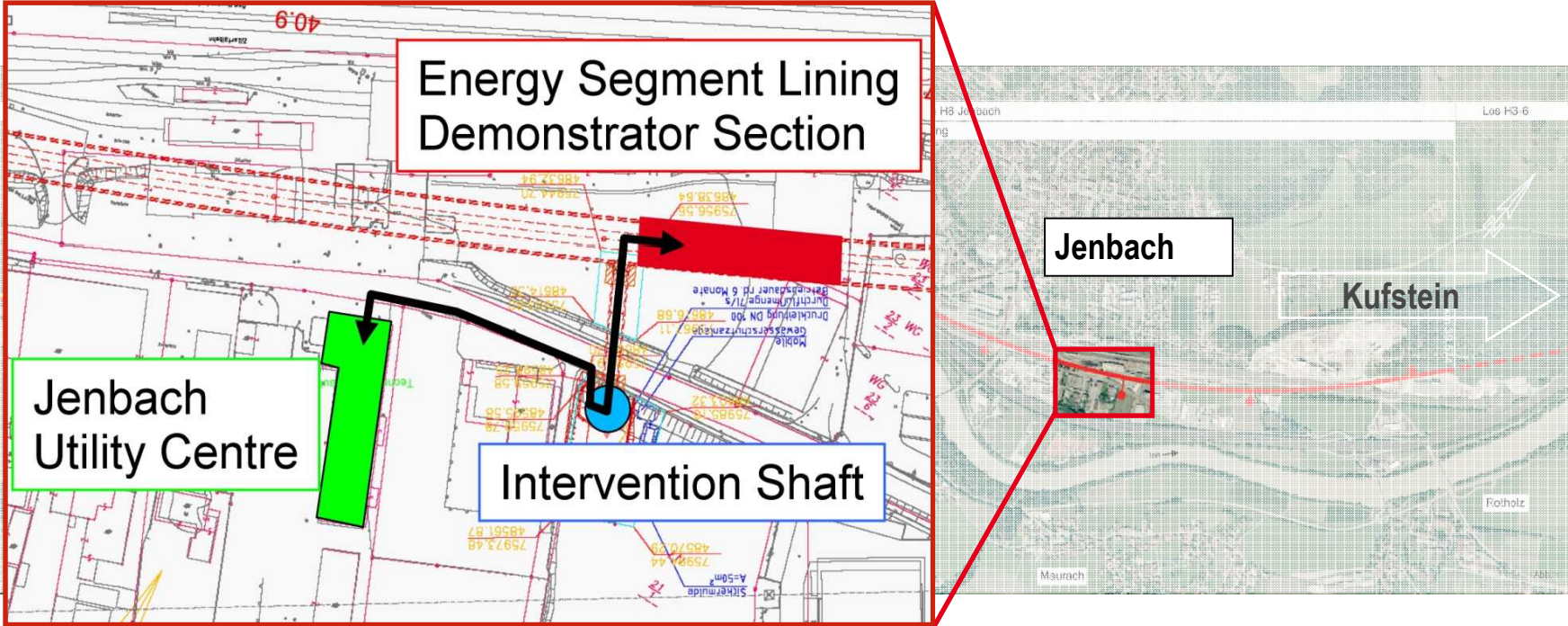

Image: Züblin

GEOHERMAL TUNNEL LINING

3. CASE STUDY JENBACH, AUSTRIA

Positioning of the absorber pipe inside the pre-fabricated Concrete Segments.

Box out section for the pipe connection.

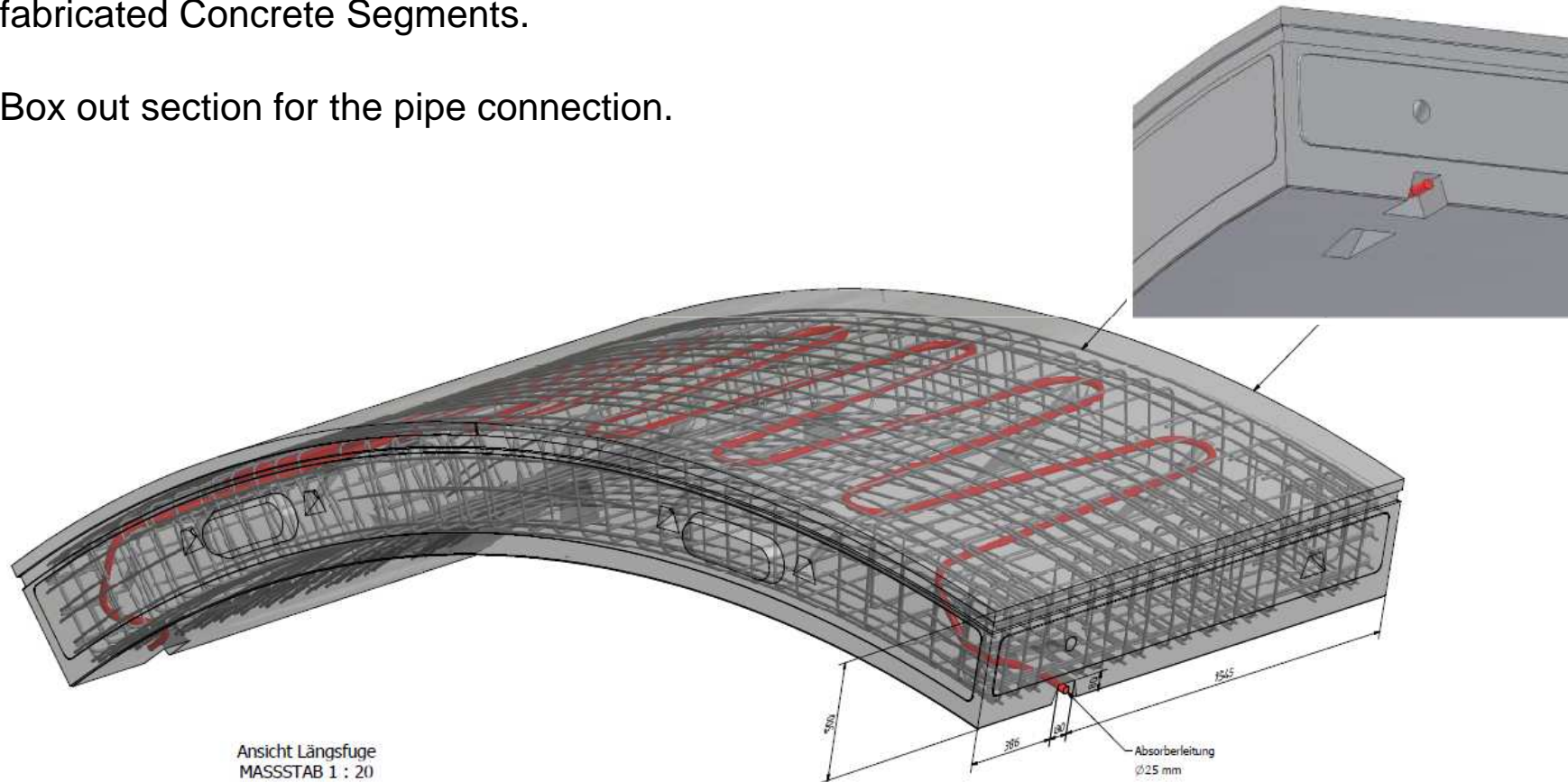

Image: Züblin

GEOHERMAL TUNNEL LINING

3. CASE STUDY JENBACH, AUSTRIA

Connection between Segments:

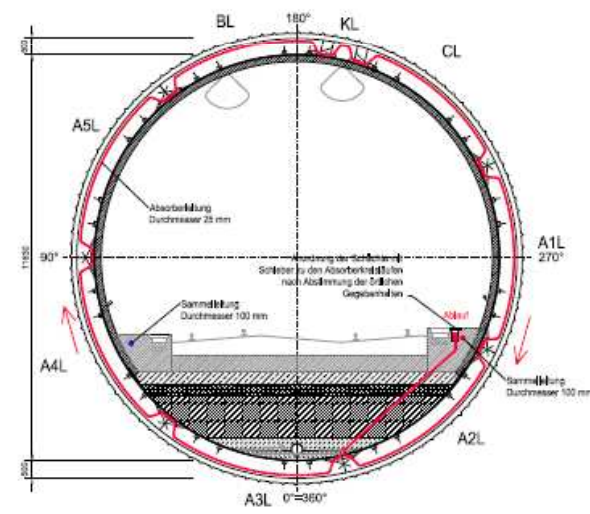
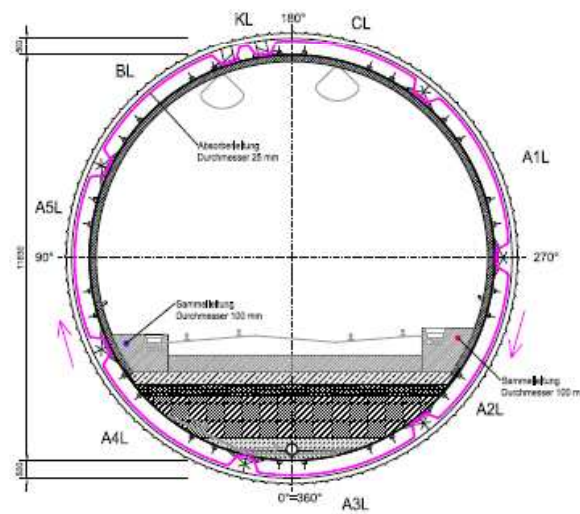
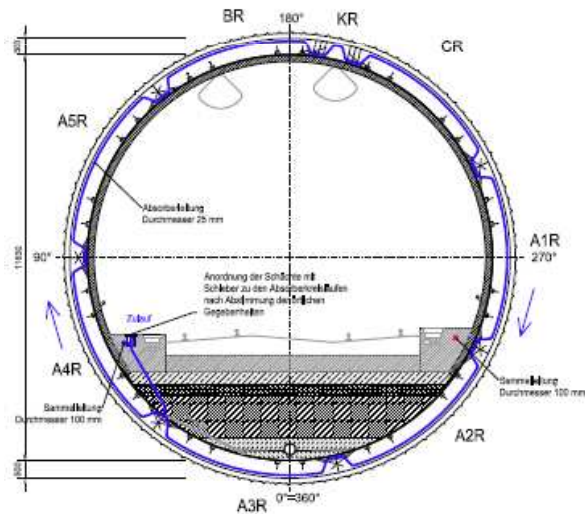
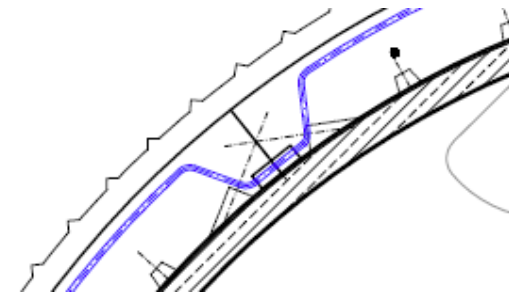

Image: Züblin

GEOHERMAL TUNNEL LINING

3. CASE STUDY JENBACH, AUSTRIA

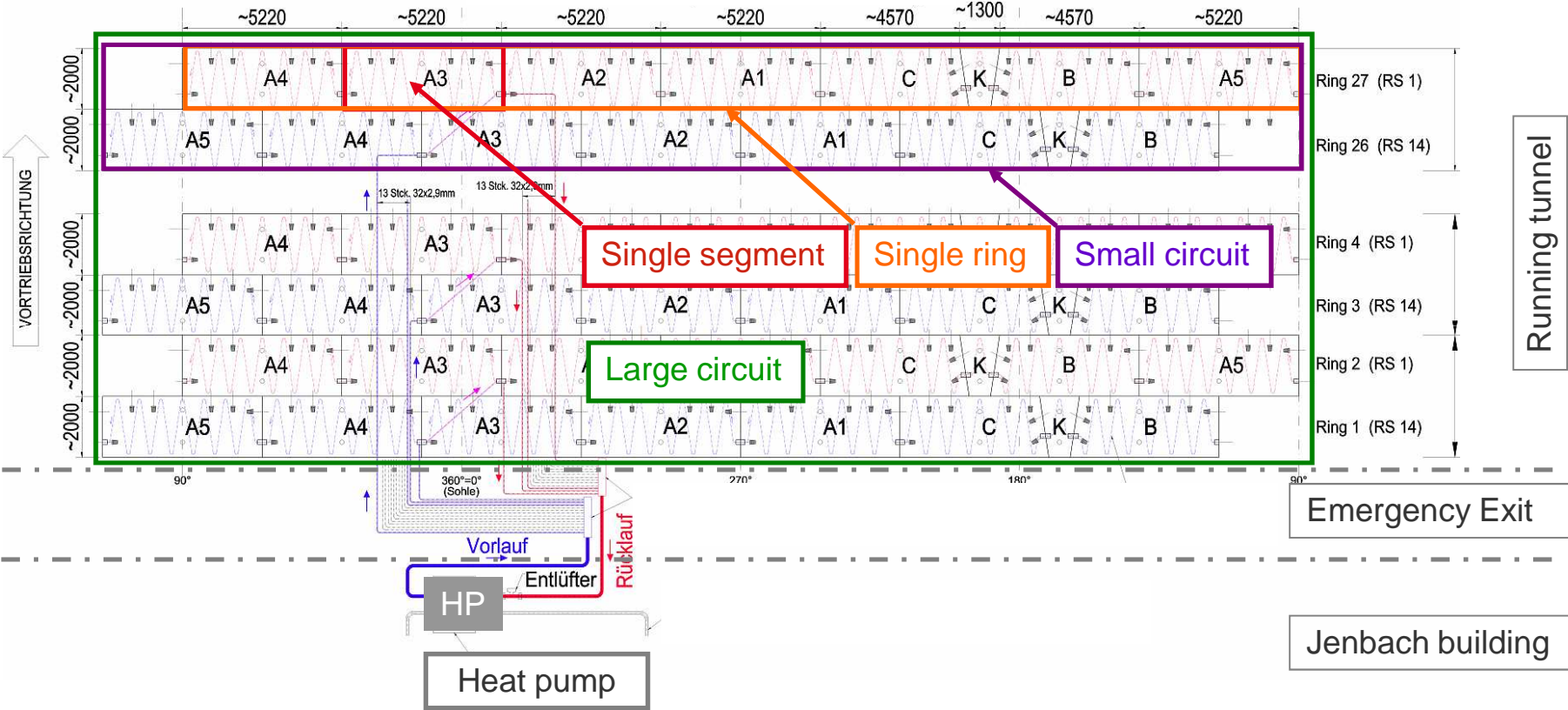

Image: Züblin

GEOHERMAL TUNNEL LINING

3. CASE STUDY JENBACH, AUSTRIA SEGMENT MANUFACTURING

Fixing of Absorber Pipe to steel mesh

- Position on the inside of the mesh
- Spacing 30 - 40 cm



GEOTHERMAL TUNNEL LINING

3. CASE STUDY JENBACH, AUSTRIA

DEMONSTRATION PROJECT JENBACH – SEGMENT MANUFACTURING



GEOTHERMAL TUNNEL LINING

3. CASE STUDY JENBACH, AUSTRIA

DEMONSTRATION PROJECT JENBACH – SEGMENT MANUFACTURING



GEOHERMAL TUNNEL LINING

3. CASE STUDY JENBACH, AUSTRIA DEMONSTRATION PROJECT JENBACH – SEGMENT MANUFACTURING

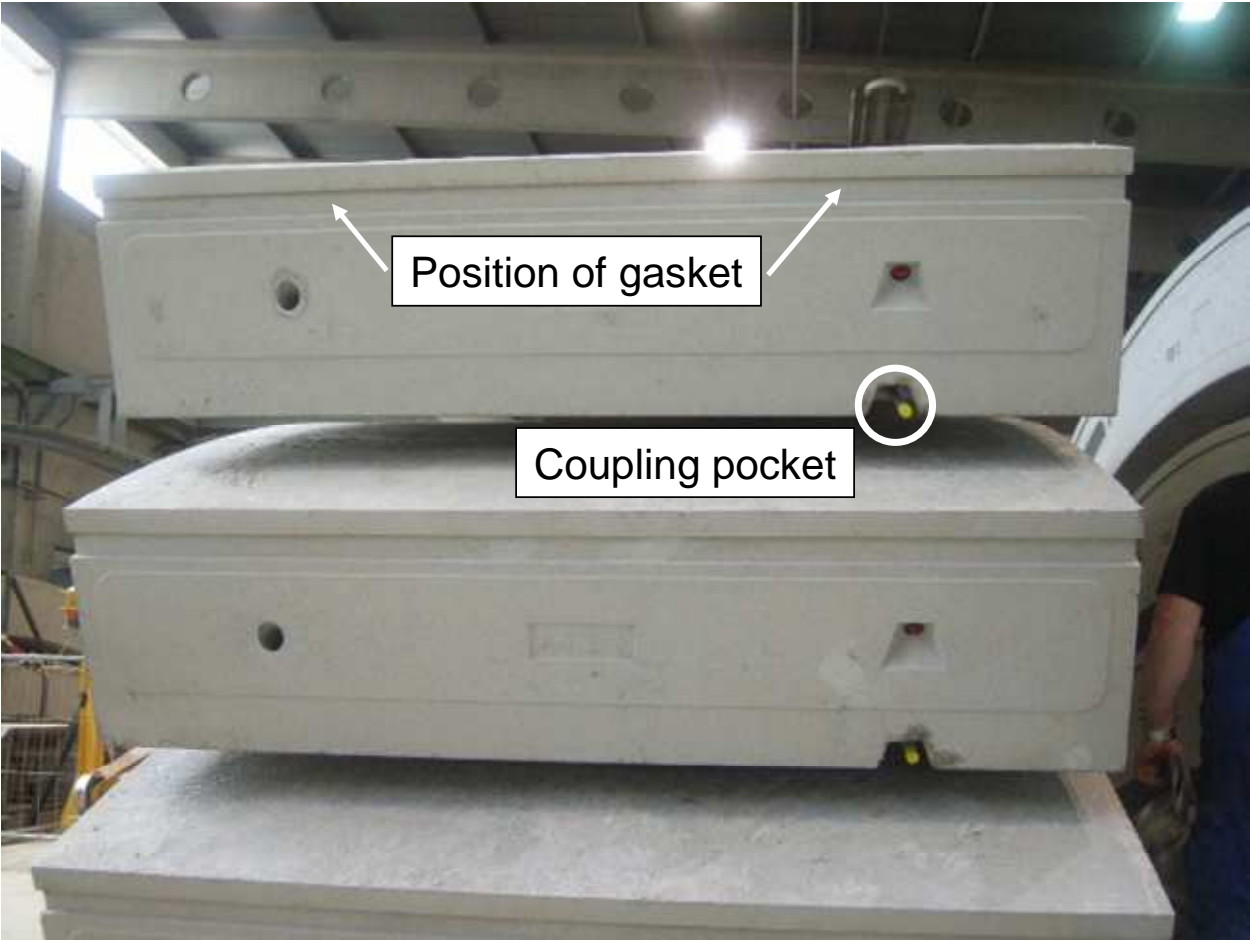
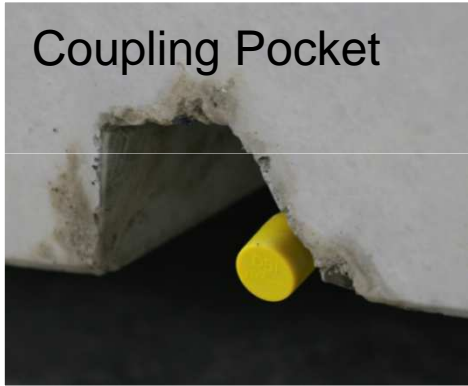

GEOHERMAL TUNNEL LINING

3. CASE STUDY JENBACH, AUSTRIA

DEMONSTRATION PROJECT JENBACH – SEGMENT INSTALLATION



GEOHERMAL TUNNEL LINING

3. CASE STUDY JENBACH, AUSTRIA

DEMONSTRATION PROJECT JENBACH – SEGMENT INSTALLATION



GEOTHERMAL TUNNEL LINING

TURNING INFRASTRUCTURE INTO ENERGY SOURCES

1. REHAU Introduction
2. Open/closed loop system
3. Principles of Geothermal Tunnel Lining
4. Case Study: Jenbach – Austria
- 5. Case Study: U6 Stuttgart – Germany**
6. Summary

GEOHERMAL TUNNEL LINING

4. CASE STUDY U6 STUTTART, GERMANY

Project Data:

U6 Stuttgart Fasanenhof

1,030 m Total Tunnel Length (2x10 m activated)

Construction: NATM (New Austrian Tunnel Method)

Tunnel diameter: 10 m

ARGE U6:

Wayss & Freytag Ingenieurbau, Frankfurt

Max Bögl, Neumarkt

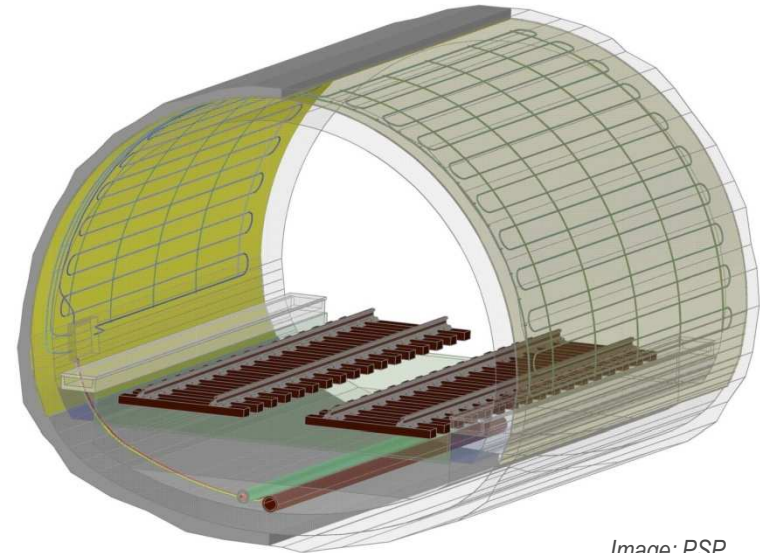

Image: PSP

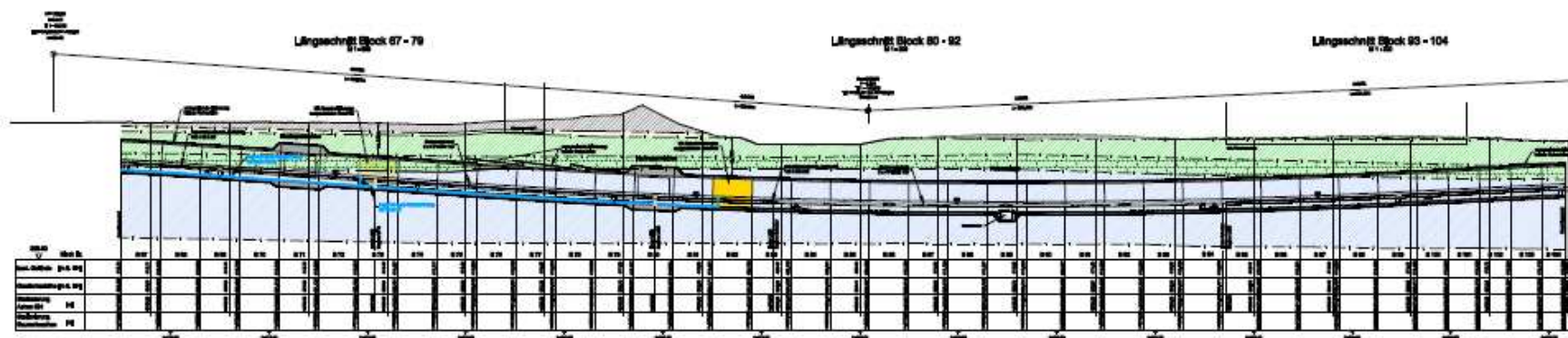

Image: Arge U6

GEOHERMAL TUNNEL LINING

4. CASE STUDY U6 STUTTART, GERMANY

Absorber pipes have been incorporated between the outer sprayed concrete and the insitu inner concrete lining .

Header pipes have been positioned in the tunnel invert level.

Project performance is monitored by the University of Stuttgart.

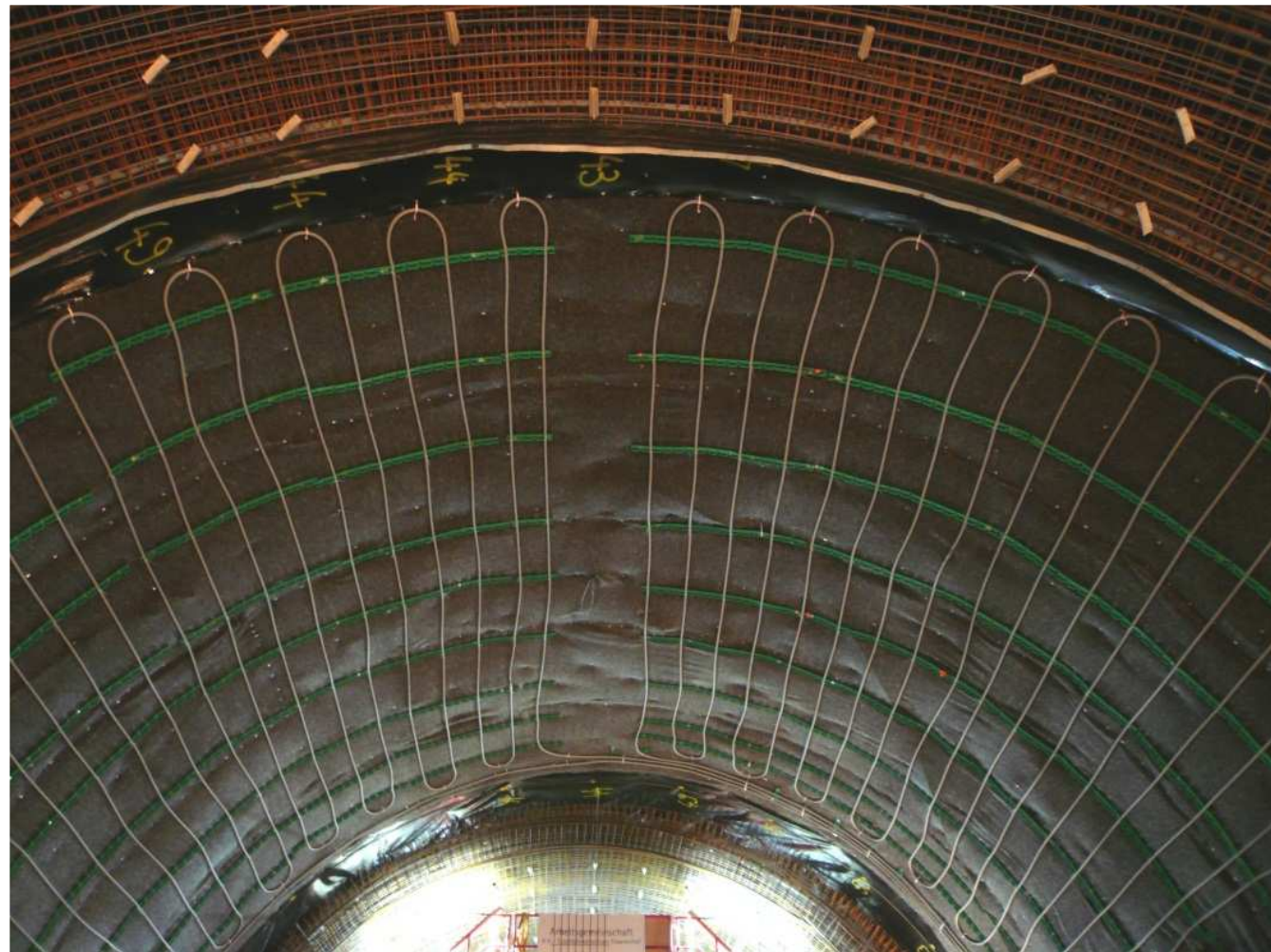

GEOHERMAL TUNNEL LINING

4. CASE STUDY U6 STUTT GART, GERMANY MONITORED DATA OF HEAT REJECTION MODE

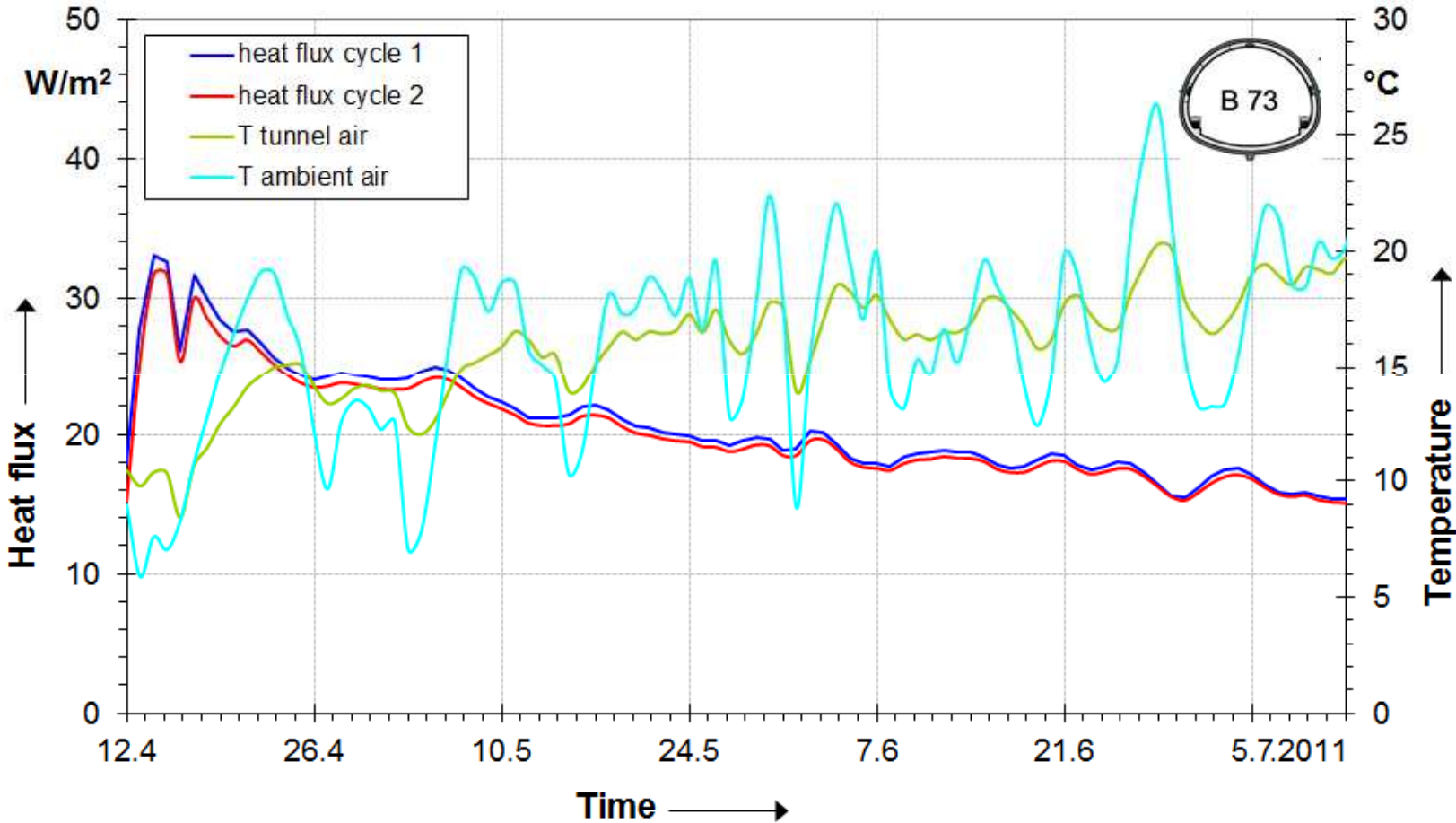

Image: GeoTU6, Universität Stuttgart, Schneider, Moormann

GEOTHERMAL TUNNEL LINING

TURNING INFRASTRUCTURE INTO ENERGY SOURCES

1. REHAU Introduction
2. Open/closed loop system
3. Principles of Geothermal Tunnel Lining
4. Case Study: Jenbach – Austria
5. Case Study: U6 Stuttgart – Germany

- 6. Summary**

GEOHERMAL TUNNEL LINING

5. SUMMARY

- **Successfully used** in projects in Germany and Austria.
- **Concrete mass and surrounding soil** of tunnel structures are used for **energy storage and/or as energy source** (Ground Source Energy).
- TEL can also be used **to cool the tunnel air** in case of heat build up through tunnel operation or high rock temperature.
- Typical **extraction rate of 10 – 30 W/m²** tunnel surface (dependant on project specific conditions).
- Extracted energy can be supplied for **above ground use**.
- Can be implemented **without project delays** and minimal extra cost when **considered during design stage**.

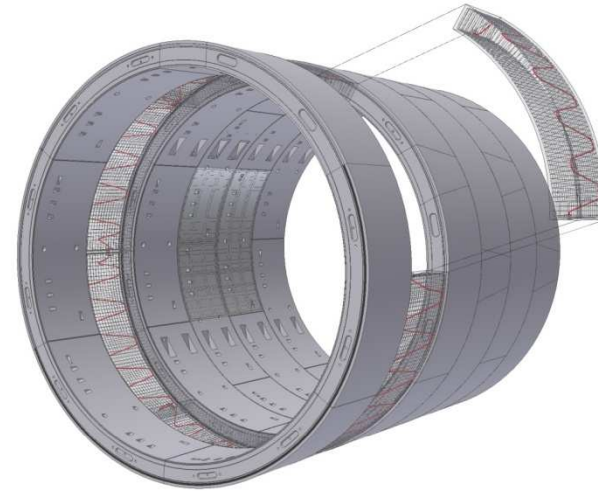

Image: Züblin

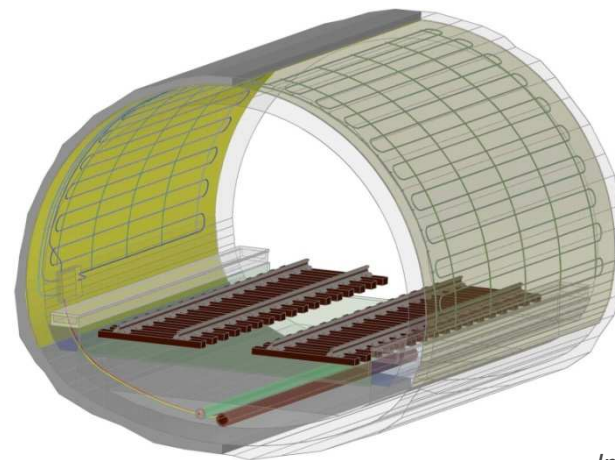

Image: PSP

GEOTHERMAL TUNNEL LINING

SUMMARY

... A WINNING CONCEPT

Hong Kong, 01.December, 2011:

Tunnel Energy Lining is awarded for the NCE-Tunnelling Award 2011 !



GEOHERMAL TUNNEL LINING

TURNING INFRASTRUCTURE INTO ENERGY SOLUTIONS

For further details please contact:

Mike Moseley
REHAU London
Mobile: +44 7970 461 722
E-Mail: michael.moseley@rehau.com

Ralf Winterling
REHAU Head Office Germany
Mobile: +49 151 2643 4750
E-Mail: ralf.winterling@rehau.com

Visit www.rehau.com/tunnelconstruction



Won Awards 2011